

W8 TOP / EASY TOUCH

sottovuoto
vacuum packaging machines



W8 TOP 40 BX

con gas inerte, soft air e AOR opzionali
with inert gas, soft air and AOR optional



W8 Easy Touch

- Comandi touch facili e intuitivi
- 10 Programmi memorizzabili dall'utente
- Programma marinatura
- Programma vuoto esterno
- Contacigli
- Non disponibile con stampante o gas
- Sollevamento coperchio automatico a mezzo di pistoncini pneumatici

Opzionali:

- Impianto per gas inerte (MAP).
- Stampante termica automatica per data, ora dati confezionamento
- A.O.R. cambio olio automatico
- SanO₃ - Brevettato - è un sistema integrato e automatico di sanificazione della camera e dei vari condotti che, tramite un generatore di ozono, riesce ad arrivare dove i tradizionali sistemi di sanificazione non arrivano. Disponibile solo per W8 TOP 40, 50 e 70

- Straordinario design riduce l'ingombro della macchina e migliora la praticità
- Campana di grande volume in plexiglass termoformato di grosso spessore sui mod. 50 e 70, ad iniezione in Tritan sui mod. 30 e 40
- Barra saldante facilmente rimovibile
- Estrema facilità di pulizia grazie alla perfetta planarità del piano di appoggio prodotto realizzato in acciaio inox AISI 304 spessore 5 mm
- Sollevamento coperchio automatico a mezzo di pistoncini pneumatici
- Supporto per buste con liquidi

Opzionali:

- Tubo per aspirazione esterna
- Vasche GN per aspirazione esterna
- Ripiano in plexiglass trasparente

W8 TOP

- Display touch, pratico e intuitivo
- Sistema di controllo elettronico con sensore di pressione, per una lavorazione precisa e veloce
- Percentuale vuoto automatico regolabile 50-100%
- Programma dedicato per liquidi
- Programmi dedicati per marinatura
- 10 programmi memorizzabili a piacere
- selezione 6 lingue
- impostazione tempo saldatura, vuoto e gas con scala 1/10 sec.
- visualizzazione percentuale vuoto e tempo residuo
- Gestione predittiva delle operazioni di manutenzione per garantire una maggior durata nel tempo
- Segnale di avviso sostituzione olio e filtro
- Protezione termica pompa
- Ciclo di preriscaldamento e pulizia olio
- Contacigli totali
- Contatore utilizzo pompa
- Scheda Wi-Fi integrata che favorisce un'attenta gestione del post vendita in remoto
- 3 anni garanzia pompa (per macchine collegate in Wi-Fi)
- Gestibile interamente tramite APP, facile ed intuitiva, scaricabile gratuitamente dagli store ufficiali

Compatibile Industria 4.0



W8 TOP 50 DX



W8 30 EASY TOUCH DX



W8 40 EASY TOUCH BX



Estrema facilità di pulizia
Easy to clean



Facile manutenibilità
Easy maintainability

- Extraordinary design reduces the footprint of the machine and improves comfort
- Bell in great development of volume plexiglass thermoformed thick on mod. 50 and 70, injection in Tritan on mod. 30 and 40
- Easily removable sealing bar
- Extremely easy to clean thanks to the perfect flatness of the support product plan made on AISI 304 stainless steel 5 mm thick
- Automatic lifting the lid by means of pneumatic pistons
- Surface for liquid bags

Optionals:

- Hose for external suction
- GN tanks for external suction
- Plexiglass support

W8 TOP

- Practical and intuitive touch screen display
- Electronic control system with pressure sensor for fast and precise processing
- Adjustable automatic vacuum percentage: 50-100%
- Dedicated programme for liquids
- Dedicated programme for marinating
- 10 different settings savable to preference
- 6 selectable languages
- Settable sealing, vacuum and gas time on a scale 1-10 sec.
- Display of vacuum percentage and time to countdown
- Scheduled management of maintenance operations to ensure longer-lasting life
- oil and filter change warning light
- Thermal pump guard
- Oil preheat and cleaning cycle
- Total rev counter
- Pump meter
- Built-in Wi-Fi card which allows careful management of after-sales service at a distance
- 3-year pump warranty (for machines connected via Wi-Fi)
- Fully manageable via APP that is easy and intuitive and can be downloaded free-of-charge from official stores

Optionals:

- Inert gas system (MAP)
- Automatic thermal printer by date, time and packing specifications
- A.O.R. - Patented - Automatic Oil Replacement
- SanO3 is an integrated and automated sanitizing system that works with an ozone generating cell to deeply sanitize the chamber and all the air pipes reaching the best result where other sanitizing procedures cannot get. Available only on W8 TOP 40, 50 and 70

W8 Easy Touch

- Easy and intuitive touch controls
- 10 Programs that can be stored by the user
- Marinating program
- External vacuum program
- Cycle counter
- Not available with printer or gas flush
- Automatic lid lifting by means of pneumatic pistons



W8 TOP 70 BX TB P



Comandi touch per mod. TOP
Touch controls for mod. TOP



Sospensione coperchio ammortizzato
Lid damper suspension system



Opzioni gas inerte e A.O.R.
(escluse le Easy)
Option inert gas and A.O.R.
(the Easy excluded)



Supporto per buste con liquidi di serie
Standard support for vacuum bags with liquids



Barra saldante standard
Single sealing bar



Doppia barra saldante W8 50 DB
Double sealing bar W8 50 DB



Tripla barra saldante W8 70 TB
Triple sealing bar W8 70 TB



Barra saldante con taglio opzionale
Optional sealing bar with cut-off wire



W8 50 DB
Ripiano in plexiglass opzionale
Optional plexiglass shelf



Stampante integrata opzionale
Optional built-in printer



Carta adesiva per stampante integrata
opzionale
Optional adhesive paper for built-in
printer



Sistema integrato e automatico di
sanificazione opzionale - Brevettato
Optional integrated and automated
sanitizing system - Patented



Utilizzo di buste goffrate per il vuoto
fuori campana
Embossed bags can be used to seal
bigger products holding them outside
the lid



Possibilità di saldare più buste
sovrapposte
More overlapped bags can be sealed
at once to speed intense work load



Cavalletto alluminio per W8 50 - opzionale con e senza ruote
mm 586x564 h.757 + h.110 mm con ruote

Aluminium table base to W8 50 - optional with or without wheels
mm 586x564 h.757 + h.110 mm with wheels





Tubo per aspirazione esterna opzionale
External suction hose optional

Contenitori GN 1/1 - 1/2 - 1/3 (h.100/150)
con coperchio inox opzionali
*Optional containers GN 1/1 - 1/2 - 1/3
(h.100/150) with s/steel cover*
0-100% vuoto / vacuum

Contenitori GN 1/1 - 1/2 - 1/3 (h.100/150)
con coperchio in Tritan opzionali
*Optional containers GN 1/1 - 1/2 - 1/3
(h.100/150) with cover in Tritan*
0-80% vuoto / vacuum



AOR[®]
AUTOMATIC OIL REPLACEMENT

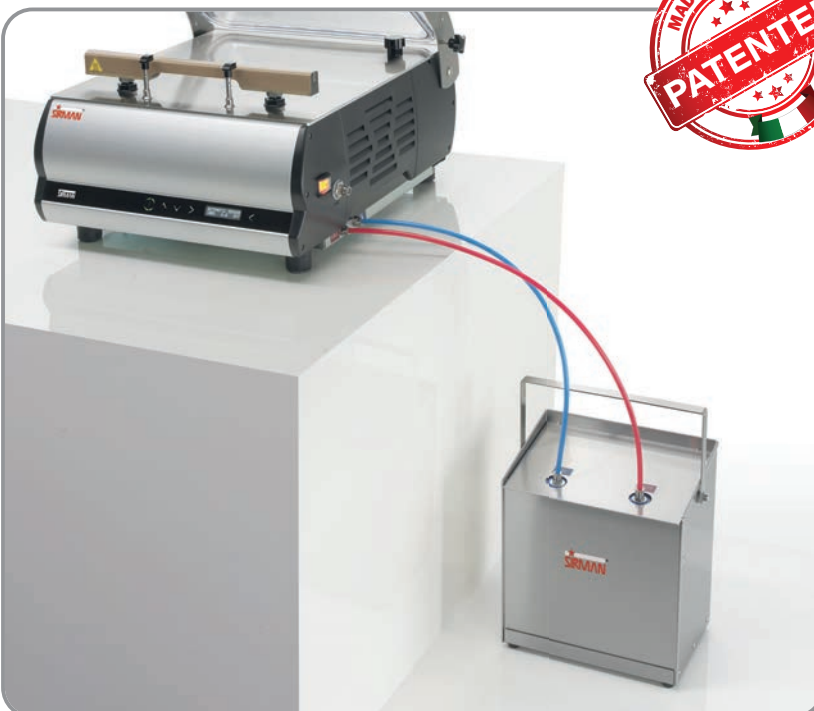

Un brevetto esclusivo di Sirman,
sempre al primo posto per tecnologia
sottovuoto e sous vide.
Gestisce il cambio olio in automatico
tramite dei serbatoi esterni che
permettono un'autonomia da 1 a 3
anni senza bisogno di interventi sulla
pompa.

La macchina provvede automaticamente
quando serve sostituire l'olio,
preservando la pompa e prolungandone
la garanzia fino a 3 anni (per macchine
connesse in Wi-Fi).
Dimensioni mm 230x330 h.341

*Automatic Oil Replacement, an exclusive
patent by Sirman, always in pole position
for vacuum and sous vide technology.
The machine automatically manages the
oil changing, preserving the pump from
damage and thus extending the warranty
of the pump to 3 years (for machines
connected via Wi-Fi).
Dimensions mm 230x330 h.341*



Buste per sottovuoto lisce μm 70 <i>Vacuum bags smooth μm 70</i> (-40°C / +40°C)	Buste per sottovuoto lisce μm 90 <i>Vacuum bags smooth μm 90</i> (-40°C / +40°C)	Buste per sottovuoto goffrate μm 105 <i>Vacuum bags embossed μm 105</i> (-40°C / +40°C)	Buste per cottura sottovuoto Cook&Chill μm 80 <i>Vacuum bags Cook&Chill μm 80</i> (-40°C / +12°C)
cm 20x30	cm 17x25	cm 16x23	cm 15x20
cm 25x35	cm 20x30	cm 20x30	cm 20x30
cm 30x40	cm 25x35	cm 25x35	cm 25x35
cm 40x50	cm 30x40	cm 30x40	cm 30x40
	cm 35x45	cm 35x45	
	cm 40x50	cm 40x50	

IDENTIFICAZIONE MODELLI

- D = Pompa DVP
- B = Pompa Busch
- X = piano appoggio inox
- 12 = pompa aspirazione 12 mc
- DB = doppia barra saldante
- TB = tripla barra saldante
- P = da pavimento

ORDERING SYSTEM

- D = DVP
- B = Pump Busch
- X = flat s/steel countertop
- 12 = suction pump 12 mc
- DB = double sealing bar
- TB = Triple sealing bar
- P = floor standing

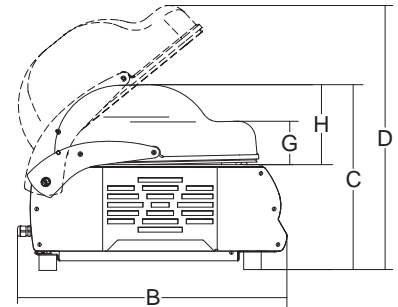
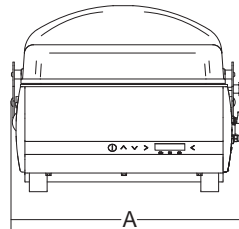
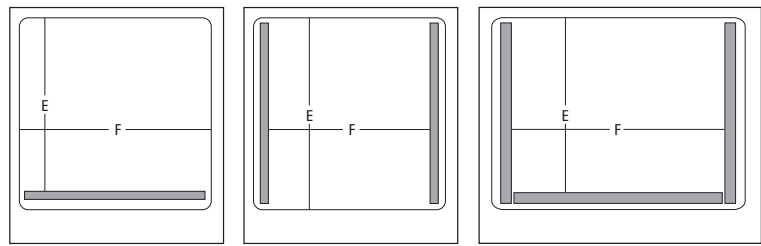

						A	B	C	D	E	F	G	H			
	kw	mc/h	mm	mm	mm	mm	mm	mm	mm	mm	mm	mm	mm	kg	mm	kg
W8 30 Easy Touch DX	0.35	1ph	8	310	340x360 h.160	402	525	408	587	334	340	95	170	38	720x570x770	48
W8 30 Easy Touch BX	0.35	1ph	8	310	340x360 h.160	402	525	408	587	334	340	95	170	38	720x570x770	48
W8 30 Easy Touch DX 12	0.45	1ph	12	310	340x360 h.160	402	525	408	587	334	340	95	170	38	720x570x770	48
W8 40 Easy Touch DX 12	0.45	1ph	12	410	430x410 h.170	493	585	422	630	390	430	99	180	54	760x640x770	64
W8 40 Easy Touch DX	0.75	1ph	21	410	430x410 h.170	493	585	422	630	390	430	99	180	56	760x640x770	66
W8 40 Easy Touch BX	0.75	1ph	21	410	430x410 h.170	493	585	422	630	390	430	99	180	56	760x640x770	66
W8 50 Easy Touch DX	0.75	1ph	21	510	545x460 h.190	609	640	420	605	430	540	90	210	70	840x870x750	86
W8 50 Easy Touch BX	0.75	1ph	21	510	545x460 h.190	609	640	420	605	430	540	90	210	70	840x870x750	86
W8 Top 30 DX	0.35	1ph	8	310	340x360 h.160	402	525	408	587	334	340	95	170	38	720x570x770	48
W8 Top 30 BX	0.35	1ph	8	310	340x360 h.160	402	525	408	587	334	340	95	170	38	720x570x770	48
W8 Top 30 DX 12	0.45	1ph	12	310	340x360 h.160	402	525	408	587	334	340	95	170	38	720x570x770	48
W8 Top 40 DX	0.75	1ph	21	410	430x410 h.170	493	585	422	630	390	430	99	180	56	760x640x770	66
W8 Top 40 BX	0.75	1ph	21	410	430x410 h.170	493	585	422	630	390	430	99	180	56	760x640x770	66
W8 Top 50 DX	0.75	1ph	21	510	545x460 h.190	609	640	420	605	430	540	90	210	70	840x870x750	86
W8 Top 50 BX	0.75	1ph	21	510	545x460 h.190	609	640	420	605	430	540	90	210	70	840x870x750	86
W8 Top 50 DX DB	0.75	1ph	21	410x2	545x460 h.190	609	640	420	605	424	428	90	210	75	840x870x750	87
W8 Top 50 BX DB	0.75	1ph	21	410x2	545x460 h.190	609	640	420	605	424	428	90	210	75	840x870x750	87
W8 Top 70 BX 40 TB P	1.1	3ph+N	40	640x1 / 410x2	780x490 h.190	877	674	1134	1368	424	660	95	200	167	1200x800x1350	180